



**Head Office:
Makati, Philippines**

**Intl. Office:
Dhaka, Bangladesh**



Mission

Services

Vision

Our Clients

About Us

saudi arabia papua new guinea arab emirates saudi arabia qatar
jordan syria united arab emirate singapore oman welder SMAW
qatar kuwait welder W pipe welder formen
angola india kazakhstan building electrician HV operator
lebanon kazakhstan chargehand operator
iran mordan in sudan h.e.operator building
libya armenia zerbaijan foreman mechanic driver
MANILA • CEBU • DAVAO • BATANGAS

Company Name East West Placement Center, Inc. (EWPCI)
Address RIZZ 1059 Metropolitan Office Building, Makati City, Philippines 1200
Contact Engr. Aman Ullah, CEO
Rizaline O. Dormiendo, HRMent
Telephone (+63 2) 896-8203 (Client Hotline)
(+63 2) 895-0911 (Application)
Fax (+63 2) 895-3585
POEA License NCC-03-0234
POEA-243-LP
Valid until 02/2011
www.eastwestplacement.com

Company Name East West Human Resource Center Ltd. (EWHRC)
Head Office 12/C Ruppur Road, 7 Kemal Ataturk Avenue, Banani, Dhaka.
Training Center House No. 10, D, Bannar Tek main Road, Turag
Dhaka, Bangladesh.
Contact Nadimun Gani, (Managing Director)
Telephone (+88 02) 8660195
Mobile (+88 0197 3018337)
Email info@eastwesthr.com
License HRM/10/01/01/01/01

RECRUITMENT FOR C
PHILIP

RECRUITMENT FOR C
AS EMPLOYMENT



RL NO. - 980

City Office

2/B Rupsha Tower
7 Kemal Ataturk Avenue
Banani, Dhaka
Bangladesh
Tel: +880-2-9822079
+880-2-9822080



Training Center

House # 51, Block # D
Bamnar Tek Main Road, Turag
Dhaka, Bangladesh
Tel: +880-2-8981393



“Empowering Man to Work”

East West Human Resource Center Ltd, recognizes the global need for employment. We want to provide our clients with world-class, personalized service and to Bangladeshis the opportunity to work overseas.

To achieve this aim:

- Continually provide our clients with worker who are **competent, reliable** and **dedicated**
- Help Bangladesh enhance their competence thereby raising the competitiveness of the workforce
- Constantly work alongside with government agencies in the welfare of our clients and workers





“We Think Ahead to Stay Ahead”

East West Human Resource Center Ltd. shall be the undisputed Leader in the country’s Recruitment Industry by continually providing our clients with world class service and competent workforce, by constantly upgrading its facilities and systems and by strengthening ties with our clients.

East West is an advocate of the Bangladeshi workers and believes in their innate capabilities and their desire to work, and we intend to bring the Bangladeshi workers to every corner of the world to make them more competitive in the global market.









About Us

Established in 2006 **East west Human Resource Center Ltd**, which is based in Dhaka, Bangladesh, provides manpower to clients of EWHRCL. East West recognizes the scarcity of skilled workers and the growing demand by employers for **Skilled categories**. East west has designed solutions targeting specific client requirements and is taking pro-active steps to recruiting.

EWHRCL has well trained Representatives in all **64 Districts and Industrial areas to source experienced candidates.**





Our Clients

CLIENT NAME	COMPANY LOGO
CONSOLIDATED CONTRACTORS COMPANY (KSA)	
CONSOLIDATED CONTRACTORS COMPANY (OMAN)	
JOANNOU & PARASKEVAIDES (KSA)	
JOANNOU & PARASKEVAIDES (OMAN)	
SAUDI OGER LTD. (KSA)	
HIDADA (KSA)	
MADINA GROUP (QATAR)	

CLIENT NAME	COMPANY LOGO
ARABIAN CONSTRUCTION COMPANY (UAE)	
AL-AJJAJ LIMITED COMPANY (QATAR)	
QATAR GENERAL ELECTRICITY & WATER CORPORATION (QATAR)	
PETROFAC (QATAR)	
DESERT LINE PROJECTS WLL (QATAR)	
IRM OFFSHORE SERVICES, (QATAR)	
KENTECH (UAE)	

Our Clients

CLIENT NAME	COMPANY LOGO
TEYSEER GROUP (QATAR)	TEYSEER GROUP  مجموعة التيسير
AEDGE (SINGAPORE)	
KEPPEL OFFSHORE & MARINE (SINGAPORE)	
KONNECT (UAE)	
SUNLIGHT INTERIORS & EXHIBITIONS SPC (BAHARAIN)	
JURONG SHIPYARD PTE LTD (SINGAPORE)	
TECHNO-BLUE W.L.L (QATAR)	

CLIENT NAME	COMPANY LOGO
ELETEX GROUP OF COMPANIES	
JURONG ENGINEERING LIMITED (SINGAPORE)	
KENTZ	 Member of the SNC-Lavalin Group
SQUARE GENERAL CONTRACTING CO. L.L.C. (QATAR)	
BINZARG CO. L.L.C (KSA)	
SEMBCORP MARINE	
GULF OIL & GAS L.L.C (UAE)	

Our Clients

CLIENT NAME	COMPANY LOGO
El-Seif (KSA)	
Shapoorji Pallonji (Qatar)	
OGASCO (UAE)	
NDT & CORROSION CONTROL SERVICES	
GULF OIL & GAS L.L.C	
AL AHD GENERAL CONTRACTING CO.	
ALPINE ENGINEERING & SERVICES PTE LTD.	
ALBANNA GROUP	
L&T Hydrocarbon Engineering	

CLIENT NAME	COMPANY LOGO
SMASCO (KSA)	
Nasser S. Al Hajri (KSA)	
AL-RAJHI (KSA)	
NOVA WATER (KSA)	
SHAWARMA KING (KSA)	
ABV ROCK GROUP LTD	
First Fix	
AL-MAJAL Group	
ASTRA FARMS	

☐ Mobilization

- EWHRCL maintains a large computerized database of applicants for easy reference.
- We currently have **over 15,200 active jobseekers** in our database who applied through our website **www.bdeastwest.com**

And the number is increasing everyday.

In a few months time, our clients will be able **to view our 'Screened Database', Download CVs** and **Shortlist** the candidates of their choice from our portal.



SERVICES

Trade Test

The company has technical and medical evaluators who can pre-screen the applicants. For trade testing, we rely on our certified personnel.

Pre-Screen

EWHRCL is staffed with qualified Technical Evaluators with long experiences in the Middle East. If the client sends representatives, the number of applicants we normally pre-screen and line up is 3 times the number that they require, unless otherwise specified by the client.

Apart from that, our Technical Evaluators Pre-Screen every single applicant who apply through our website and send them in to our 'Screened Database'.



SERVICES

❑ Selection

EWHRCL has a highly qualified technical team who can perform the selection of workers in behalf of the clients. Some of our clients prefer that we conduct the selection for them. The company takes full responsibility for the qualifications of each worker that it selects.

In 2014 & 2015, J&P, Oman has employed 200+ personnel selected by EWHRCL with zero complain.

❑ Travel Documents Processing

EWHRCL also assists in the processing of the applicants' documents, like their passports, Smart Card, Medical, Police Clearance and the likes, to expedite their deployment. This is hastened by the assistance of our Liaison Officers to various institutions and government offices.



SERVICES

❑ Reports

EWHRCL regularly sends its clients various weekly reports to help them monitor the progress of the recruitment. We also answer all client queries within a span of 24 hours after receiving such queries.

After a project's completion, the company submits a final report to the client, which indicates visa and ticket utilization with the corresponding applicant names and the date of deployment.

In near future, all these reports will be available to our clients anytime through our interactive website. Queries and other correspondences can be facilitated in the website.

❑ Deployment Notification

The workers' flight schedules are forwarded to their respective employers three days in advance. Employers are immediately notified of any changes. EWHRCL also notifies the employers of the categories, salaries, blood groups, photo and EW Jackets along with other information.



SERVICES

❑ Pre-Flight Briefing

The company has had a PR Section to address our relations with the deployed workers on a more personal level.

Our pre-departure orientations impart to the workers how to manage employer-worker problems or disputes to keep it from escalating.

We also brief them regarding their Travel Plan, Emergency Contacts, Culture & Customs of the destination country, Working Environment and so on.

❑ Airline Tickets

The clients may either send the PTA or have EWHRCL purchase the tickets locally in their behalf. We can acquire the tickets here directly from the various airlines affording our clients more favorable rates and booking privileges.



SERVICES

❑ Client Accommodation

EWHRCL maintains corporate accounts in various Five Star and Three Star hotels at discounted rates close to corporate office and training center.

❑ Airport

EWHRCL has Public Relations Officers to assist our clients in their Accommodations and chauffeured service to and from the airport.

❑ Deployment Period

EWHRCL requires a lead-time of **30 working days** for deployment of required workers **after receiving E-Wakala** from the employer.





Up until 2016, East West
has deployed thousands
of skilled & unskilled
jobseekers in following
categories:

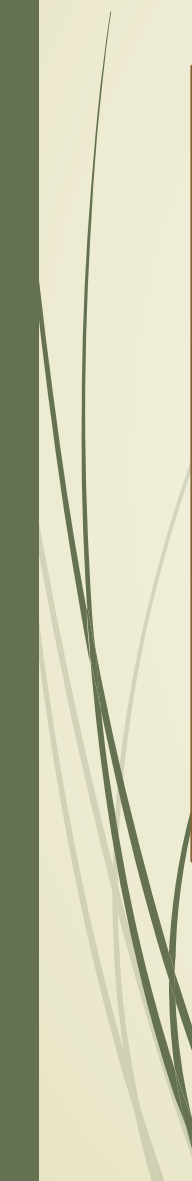

Categories

- 1 ALUMINIUM FABRICATOR
- 2 A/C TECHNICIAN
- 3 BLASTING PAINTER
- 4 BACKHOE OPERATOR
- 5 BUILDING ELECTRICIAN
- 6 CABLE PULLER
- 7 CHARGEHAND ELECTRICAL
- 8 CHARGEHAND EQUIPMENT
- 9 CHARGEHAND HYDROTEST
- 10 CHARGEHAND MECHANICAL
- 11 CHARGEHAND MILLWRIGHT
- 12 CHARGEHAND PIPE FABRICATION
- 13 CHARGEHAND PIPING
- 14 CHARGEHAND RIGGING
- 15 CHARGEHAND STEEL ERECTOR
- 16 CHARGEHAND STEEL FABRICATION
- 17 CHARGEHAND WELDING
- 18 CLIENTS SUPPORT TECHNICIAN
- 19 COMPUTER OPERATOR
- 20 CONSTRUCTION LABOUR
- 21 CRANE OPERATOR
- 22 CONTROL ASSISTANT
- 23 CO-ORDINATOR SERVICE CORDINATION
- 24 DIESEL MECHANIC
- 25 DOZER OPERATOR
- 26 DUCT FABRICATOR
- 27 DUCT SUPERVISOR
- 28 DRIVER OPERATOR
- 29 ELECTRO MECHANICAL ENGINEER
- 30 ELECTRO MECHANICAL TECHNICIAN
- 31 EINGINEER CIVIL CONTRACTOR
- 32 ELECTRICAL FOREMAN
- 33 ELECTRICIAN
- 34 ELECTRICIAN HV SIDE
- 35 ENGINEER CONSTRUCTION
- 36 ENGINEER CIVIL
- 37 ENGINEER OVER HEAD LINE
- 38 ENGINEER REINFORCEMENT
- 39 ENGINEER TELECOMUNICATION
- 40 ENGINEER (CABLE)
- 41 ENGINEER (RURAL AREA SUBSTATION)
- 42 ENGINEER (TOWN AREA SUBSTATION)
- 43 ENGINEER (TRANSMISSION PROTECTION)
- 44 EXCAVATION LABOUR (OVERHEAD LINE)
- 45 FINISHING CARPENTER
- 46 FITTER
- 47 FOREMAN MILLWRIGHT FITTER
- 48 FOREMAN ALUMINIUM FABRICATOR
- 49 FOREMAN CIVIL
- 50 FOREMAN ELECTRO MECHANICAL
- 51 FOREMAN ELECTRONICS
- 52 FOREMAN MAINTENANCE

Categories

- 53 FOREMAN MECHANICAL
- 54 FOREMAN PIPING
- 55 FOREMAN RIGGER
- 56 FOREMAN SCAFFOLDER
- 57 FOREMAN STEEL ERECTOR
- 58 FOREMAN STEEL FABRICATOR
- 59 FOREMAN THAI ALUMINIUM
- 60 FORK LIFT OPERATOR
- 61 FOREMAN NCC/DGCE
- 62 FOREMAN CABLE JOINTING
- 63 FURNITURE PAINTER
- 64 GRADER OPERATOR
- 65 GRINDER
- 66 GENERAL WORKER
- 67 GYPSUM WORKER
- 68 H.E. MECHANIC
- 69 HEAVY EQUIPMENT OPERATOR
- 70 HEAVY DRIVER
- 71 HELPER MECHANICAL
- 72 HELPER WELDER
- 73 HOUSE KEEPER
- 74 HOUSE KEEPING SUPERVISOR
- 75 HYDROTEST TECHNICIAN
- 76 HYDROTEST FITTER
- 77 HV/LV CABLE JOINTER
- 78 INDUSTRIAL ELECTRICIAN
- 79 INSPECTOR (HVAC)
- 80 INSTRUMENT FITTER
- 81 INSTRUMENT TECHNICIAN
- 82 INSPECTOR - CIVIL
- 83 INSPECTOR (ELEC / MECH)
- 84 INSPECTOR (FIRE & SAFETY)
- 85 INTERNAL AUDITOR
- 86 IT SYSTEM ADMINISTRATOR
- 87 IT TECHNICIAN
- 88 INDS. BUILDING ELECTRICIAN
- 89 INSPECTOR CIVIL
- 90 JCB OPERATOR
- 91 JOINTER (CABLE)
- 92 LAUNDRY WORKER
- 93 LIGHT DRIVER
- 94 LINEMAN
- 95 MACHINE OPERATOR
- 96 MAINTENANCE TECHNICIAN
- 97 MASON
- 98 MECHANICAL MAINTENANCE ENGINEER
- 99 MECHANICAL MAINTENANCE TECHNICIAN
- 100 MEP TECHNICIAN
- 101 METAL PAINTER (BRUSH)
- 102 METAL PAINTER (SPARY)
- 103 MILLWRIGHT FITTER
- 104 NDT TECHNICIAN

Categories

105	OPERATOR PUMP STATION	131	STEEL ERECTOR
106	PIPE FABRICATOR	132	STEEL FABRICATOR
107	PIPE FITTER	133	STEEL FIXER / ROD BINDER
108	PLUMBER	134	STRUCTURAL FABRICATIR
109	POWER ELECTRICIAN	135	STRUCTURAL FITTER
110	PUMP STATION OPERATOR	136	SUPERVISOR
111	PUMP TECHNICIAN / OPERATOR	137	SUPERVISOR (SCADA)
112	PWHT TECHNICIAN	138	SS POLISHER
113	PROJECT CHIEF ACCOUNTANT	139	TECH. WTP
114	PAINTER	140	TILES FITTER
115	PAINTER (WALL)	141	TIME KEEPER
116	Q.C INSPECTOR	142	TOPOGRAPHIC SUPERVISOR
117	Q.C INSPECTOR EQUIPMENT	143	TRAINEE Q.C INSPECTOR
118	Q.C INSPECTOR TRAINEE	144	TECHNICAL ASSISTANT
119	Q.C INSPECTOR PIPING	145	TECHNICIAN - STANDBY OFFICE
120	Q.C INSPECTOR WELDING	146	TECHNICIAN INSTALLER
121	RIGGER	147	TECHNICAL ASSISTANT DGCC
122	SUPERVISOR ELECTRICAL	148	WELDER GTAW
123	SAFETY OFFICER	149	WELDER GTAW+SMAW
124	SAFETY SUPERVISOR	150	WELDER MIG
125	SAND BLASTER	151	WELDER SMAW
126	SCAFFOLDER	152	WELDER STAINLESS STEEL (SS)
127	SERVICE TECHNICIAN	153	WELDER (TIG)
128	SHEET METAL WORKER	154	WELDER
129	SHUTTERING CARPENTER	155	WELDER 2 SS
130	SIDE BOOM OPERATOR		



Information Systems

The company's information system is the key to providing fast, accurate and reliable service.

Its network of over 35 computers is protected by a comprehensive virus defense system, spam filter and firewall.

Its high speed server allows jobseekers to log in, post CVs and the company's Mobilization team to download, screen and upload interview data at the same time.



Interview Management System (IMS):

EWHRCL uses its own purpose built application for Interview and Selection. The IMS automatically generate reports at the end of each interview session with all particulars including candidate details, grade achieved, offered salary, etc. and can hand over the report to the delegates right after the interview session.

Recruitment Management System (RMS):

The RMS is a fully integrated database system lined with 'Interview Management System' (IMS). This system manages information from all stages of the recruitment process, from recruitment to pre-screening, processing, medical fitness status to deployment. Utilizing the RMS, the processing time has been dramatically cut down.

✓ Website

The website (<http://www.bdeastwest.com/app>) allows applicants to view and apply current vacancies.

- Clients will be able to view available categories (under construction).
- Clients will also be able to download requested CVs through the website in a couple of months.
- It will later be redesigned to become interactive and integrated to the RMS, which is currently undergoing extensive development.
- They will be able to view various, visa utilization and final mobilization.
- Clients will even be able to post complaints, queries and comments online and we will respond within 12 hours.





Empowering man to work

East West Placement Center Inc. recognizes the global need for employment. We...

We think ahead to stay ahead

East West human Resource Center, Inc. shall be the undisputed leader in the...

EW Training Center

A two storied build with a total floor area of 23100 sq.ft is now operational,...

Human Resource Center

EAST WEST Human Resource Center Limited, Dhaka, Bangladesh is a branch office...

East West - Philippines



EWPCI



LEEDS HR Solutions



East West Engineering



East West Training Center



East West Learning Center



✓ Internet Video Conferencing

Employers may conduct their interviews from the comfort of their own offices in their home countries via Internet video conferencing using Skype.



We have served several clients who conducted their interview through Skype and selected a number of Engineers and Technicians.



EAST WEST TRAINING AND CONTRACTORS COMPANY LTD.



Due to the increased global need of skilled workers, East West is now developing the resource of qualified candidates by training them.

East West Human Resource Center Ltd, built its own Training Facilities **EAST WEST TRAINING & CONTRACTORS COMPANY LTD.** to cater the demands for skilled workers, also we arranged access to affiliates training school, provides tailor -made course for candidates with or without basic background to develop them into highly qualified workers.

Employers who chose not to select from our pool of trained candidates may also opt to send their own workers to our training center for upgrading to their workforce.

Established in 2007, EWTCCL has **28,800 sqft. Training facilities**, complete with welding booth & brand new equipment, spacious classrooms to accommodate large groups, highly skilled trainers to create highly skilled workers, caters training for mechanical, E & I and other skilled categories.

Training Facility

Total Area	: 28,800 sq. feet
Number of Floors	: 2
Number of Interview Rooms	: 6
Number of Conference Rooms	: 1
Number of Rooms for Processing and Documentation	: 2
Number of Class Rooms	: 3
Number of Teacher's Rooms	: 1
Number of Welding Booth	: 25
Number of Pipe Fabrication Booth	: 12
Number of Booth for Mason	: 24
Number of Booth for Steel Fixers	: 18



BOARD OF DIRECTORS



Engr. A.T.M Amanullah

Chairman & CEO

EAST WEST PLACEMENT CENTER, INC Manila, Philippines.

EAST WEST HUMAN RESOURCE CENTER LTD. Dhaka, Bangladesh.

EAST WEST TRAINING & CONTRACTORS COMPANY LTD. Dhaka, Bangladesh

Mobile: +639175290745, +6596189546,

E-mail: auewpci@yahoo.com



Shahjahan Bhuiyan

Managing Director & CEO

EAST WEST HUMAN RESOURCE CENTER LTD.

Dhaka, Bangladesh.

Mobile : 00966 50 349 6211 (KSA), +88 0171 330 4408 (Bangladesh)

E-mail : s.bhuiyan@eastwestgrp.net



Nadimun Gani

Director

EAST WEST HUMAN RESOURCE CENTER LTD.

Dhaka, Bangladesh.

Managing Director EAST WEST TRAINING & CONTRACTORS COMPANY LTD. Dhaka, Bangladesh.

Mobile : +88 01973 018 337, +88 01713 018 337

E-mail : ngani@bdeastwest.com, ewngani@gmail.com



Ali Haider Chowdhury

Director

EAST WEST HUMAN RESOURCE CENTER LTD.

Dhaka, Bangladesh.

Mobile : +88 0181 926 2176, +88 0171 515 7711

E-mail : a.chowdhury@eastwestgrp.net



Navil Aman

Director

EAST WEST HUMAN RESOURCE CENTER LTD.

Dhaka, Bangladesh.





Head Office

East West Placement Center, Inc.

Address

RIZZ 1059 Metropolitan Ave., Makati City, Philippines 1200

Contact

Engr. Aman Ullah, Chairman/CEO

Telephone: (+63 2) 896-8203, (+63 2) 895-6911 Ext:102

Mobile no: +63 917 529 0745 (Philippines)

+65 961 895 46 (Singapore)

Email: aullah@eastwest.com.ph
eastwest@eastwest.ph

<http://www.eastwest.com.ph>

International Office

East West Human Resource Center Ltd.

RL NO. - 980

Address

2/B Rupsha Tower, 7 Kemal Ataturk Avenue,
Banani, Dhaka,
Bangladesh.

Contact

Nadimun Gani, Managing Director, EWTCCCL

Cell: +8801713018337, +8801973018337

Email: ewngani@gmail.com
ngani@bdeastwest.com

Website

<http://www.bdeastwest.com>



City Office

**East West Human Resource
Center Ltd.
Dhaka Bangladesh**

In order to comply with market growth and new market entry, East West Human Resource Center Ltd. has 2000 sq. feet office facility in the heart of Dhaka city. This office offers easy access to the jobseekers from all over the country. The city office is only 15 minutes' drive from the airport and 30 minutes from the East West Training Center. This allow our clients to visit both our facilities in a short period of time.



Training and Interview Facilities

East West Training & Contractors Company Ltd.
Dhaka Bangladesh



A 28,800 sqft. Training facilities, complete with welding booth & brand new equipments, spacious classroom to accommodate large groups, highly skilled trainers to create highly skilled workers, caters training for mechanical, E & I and other skilled categories.



Training & Interview Facilities



Training & Interview Facilities: Welding Section



Training & Interview Facilities: Aluminum MIG Welding



Training & Interview Facilities: Aluminum MIG Welding

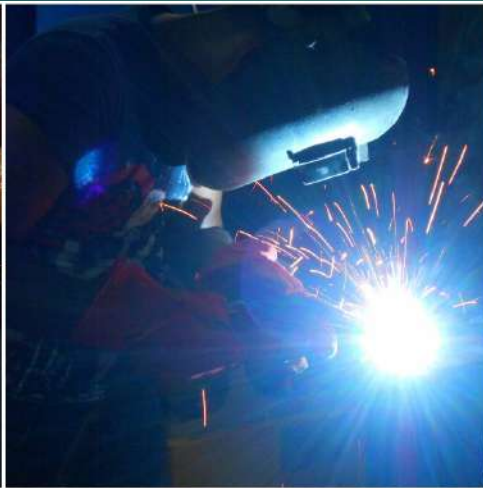

Training & Interview Facilities: Welding Section



Training & Interview Facilities: Fitter & Fabrication



Training & Interview Facilities: Fabrication Section (Ship Building)

FABRICATION Section

Practical Class in Fabrication Section



FABRICATION DRAWING

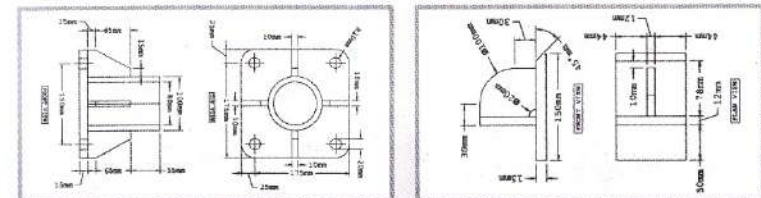
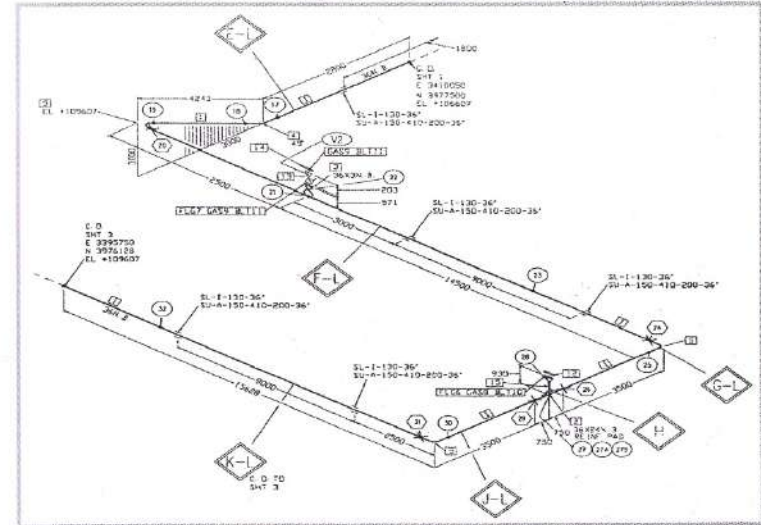
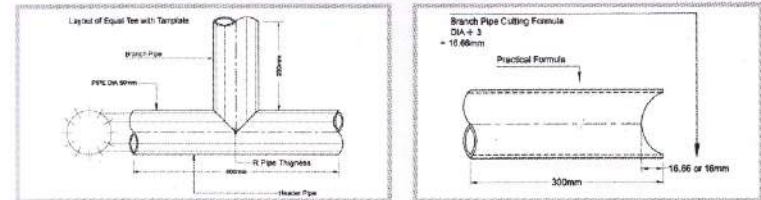

Training & Interview Facilities: Scaffolding Section



Training & Interview Facilities: Electrical Section



ELECTRICIAN & WELDER

TRAINING FOR **GAZIPUR ZELLA PARISHAD** CONDUCTED
BY **EAST WEST**

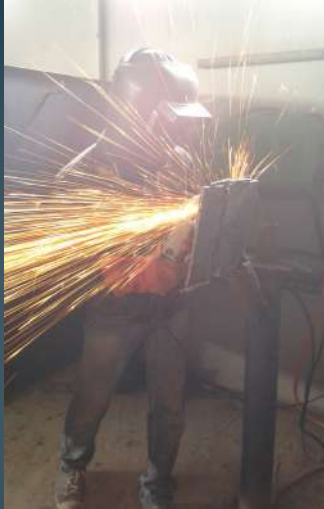

Training & Interview Facilities: Civil Section



Training & Interview Facilities: Housekeeping





Thank You.